



YBBP-W、YBBP-TH、YBBP-THW
系列隔爆型变频调速
三相异步电动机 (机座号 80~355)

YBBP-W、YBBP-TH、YBBP-THW Series
Flameproof Variable-frequency Adjustable-speed
Induction Motors
(Frame 80 ~ 355)

使用说明书

Operation Manual

安徽皖南电机股份有限公司
Anhui Wannan Electric Machine Co.,Ltd

衷心感谢您选购、使用皖南电机。

在使用电动机之前，请扫码仔细阅读本说明书，以便您正确的使用和维护。

1 产品概述

我公司生产的 YBBP 系列隔爆型变频调速三相异步电动机，是在 YB3 系列隔爆型三相异步电动机的基础上派生的隔爆型变频调速电机产品，该产品获得了国家防爆电气产品质量监督检验测试中心颁发的“防爆合格证”，并取得了由国家质量监督检验检疫总局颁发的“全国工业产品生产许可证”。

YBBP 系列隔爆型变频调速三相异步电动机符合 JB/T 11201.3-2015《隔爆型变频调速三相异步电动机技术条件 第 3 部分：YBBP-W、YBBP-TH、YBBP-THW 系列隔爆型变频调速三相异步电动机（机座号 80～355）要求》，按照 GB/T 3836.1-2021《爆炸性环境用电气设备第 1 部分通用要求》和 GB/T 3836.2-2021《爆炸性环境用电气设备 第 2 部分隔爆型“d”》的要求，制成隔爆型。其防爆标志为 Ex db II AT4 Gb、Ex db II BT4 Gb。产品适用于工厂（Ex db II AT4 Gb、Ex db II BT4 Gb）含有 II 类 A、B 级 T1～T4 组可燃性气体或蒸汽与空气形成的爆炸性混合物的场所。

2 产品型号及名称

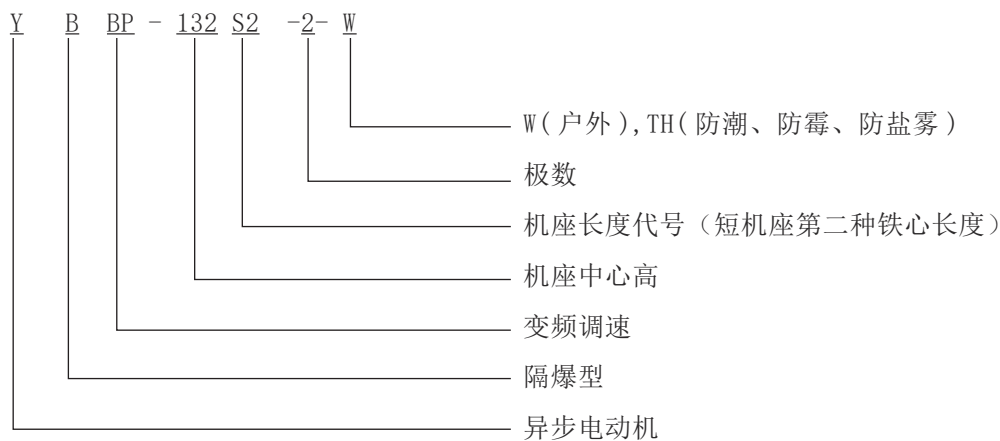

3 使用范围及使用条件

3.1 适用常见可燃性气体、蒸汽级别、温度组别举例见表 1。

表 1

级 别	引燃温度组别			
	T1	T2	T3	T4
II A	甲烷、乙烷、丙烷、 苯乙烯、甲苯、二甲 苯、一氧化碳、醋酸	丁烷、丙烷、乙苯、 甲醇、乙醇、丙醇、 本醇	戊烷、己烷、庚烷、 辛烷、癸烷、环己烷 煤油、柴油、汽油	
II B	丙炔、环丙烷、 焦炉煤气	乙烯、丁二烯环氧乙 烷、一环氧丙烷	二甲醚、丙烯醛、甲 氢糠醇四氢呋喃、硫 化氢	乙基甲基醚 二乙醚 四氟乙烯

3.2 运行使用条件

- 3.2.1 海拔不超过 1000m。
- 3.2.2 环境空气温度随季节而变化，但最高不超过 40℃，最低为 -15℃。
- 3.2.3 环境空气最大相对湿度为 90%，同时该月月平均最低温度不高于 25℃。
- 3.2.4 电动机额定电压为 380V、，额定频率为 50Hz，绝缘等级为 F 级。
- 3.2.5 电动机 3kW 及以下为 Y 接法 (380V)； 3kW 以上的电动机，为△接法。
- 3.2.6 电动机的定额是以连续工作制 (S1) 为基准的连续定额，允许满压启动。
- 3.2.7 电动机外壳最高表面温度 (温度计法) 在规定允许最不利的工作条件下应不超过 130℃。
- 3.2.8 电动机运行时，电源电压和频率与额定值的偏差按 GB/T755 的规定。

3.3 主要技术参数见表 2 和表 3

表 2 机座号与转速及标称功率的对应关系

机座号	同步转速 r/min					
	3000	1500	1000	750	600	
	功率 kW					
80M1	0.75	0.55	0.37	0.18	-	
80M2	1.1	0.75	0.55	0.25		
90S	1.5	1.1	0.75	0.37		
90L	2.2	1.5	1.1	0.55		
100L1	3	2.2	1.5	0.75		
100L2		3		1.1		
112M	4	4	2.2	1.5		
132S1	5.5	5.5	3	2.2		
132S2	7.5					
132M1	-	7.5	4	3		
132M2			5.5			
160M1	11	11	7.5	4		
160M2	15			5.5		
160L	18.5	15	11	7.5		
180M	22	18.5	-	-		
180L	-	22	15	11		
200L1	30	30	18.5	15		
200L2	37		22			
225S	-	37	-	18.5		
225M	45	45	30	22		
250M	55	55	37	30		
280S	75	75	45	37		
280M	90	90	55	45		
315S	110	110	75	55		45
315M	132	132	90	75		55
315L1	160	160	110	90		75
315L2	200	200	132	110		90
355S1	(185)	(185)	160	132		
355S2	(200)	(200)				

表 2 (续)

机座号	同步转速 r/min				
	3000	1500	1000	750	600
	功率 kW				
355M1	(220)	(220)	(185)	160	110
355M2	250	250	200		132
355L1	(280)	(280)	(220)	(185)	160
355L2	315	315	250	200	(185)

注：1 带括号的为不优先推荐规格。
2 S、M、L 后面的数字 1、2 分别代表同一机座号和转速下不同的功率。

表 3 标称功率、额定转矩及调速范围的对应关系

标称功率	额定转矩 N·m					恒转矩 调速范围 Hz	恒功率 调速范围 Hz
	2P	4P	6P	8P	10P		
0.18	-	-	-	2.2	-	5-50	50-100
0.25			-	3.1			
0.37			3.5	4.7			
0.55			3.5	5.2			
0.75	2.3	4.7	7.1	9.5			
1.1	3.5	7.0	10.5	14.0			
1.5	4.7	9.5	14.3	19.0			
2.2	7.0	14.0	21.0	28.0			
3	9.5	19.0	28.6	38.1			
4	12.7	25.4	38.1	50.8			
5.5	17.5	35.0	52.5	70.0			
7.5	23.8	47.7	71.6	95.4			
11	35.0	70.0	105.0	140.0			
15	47.7	95.4	143.2	191.0			
18.5	58.8	117.7	176.6	235.5			
22	70.0	140.0	210.0	280.1			
30	95.4	190.9	286.4	382.0			
37	117.7	235.5	353.3	471.1			
45	143.2	286.4	429.7	573.0			
55	175.0	350.1	525.1	700.3	875.4		
75	238.7	477.7	716.1	955.0	1193.7	3-50	
90	286.4	572.9	859.4	1146.0	1432.5		
110	350.1	700.2	1050.3	1400.6	1750.8		
132	420.1	840.3	1260.4	1680.8	2101.0		
160	509.2	1018.5	1527.8	2037.3	2546.6		
(185)	588.6	1177.6	1766.5	2355.6	2944.5		
200	636.6	1273.2	1909.8	2446.6	-		
(220)	700.2	1400.4	2100.9	-			
250	795.7	1591.5	2387.2				-
(280)	891.2	1782.5	-				
315	1002.6	2005.2					

3.4 电动机的结构及安装型式见表 4

表 4

机座号	结构及安装代号 (IM)
80~160	B3、B5、B6、B7、B8、B35、V1、V3、V5、V6、V15、V35、V37
180~280	B3、B5、B35、V1
315~355	B3、B35、V1

4 主要结构

4.1 电动机的接线盒位于电动机顶部，制成三个或六个接线端子。适用于橡套电缆（或塑料电缆）和钢管布线的两种结构，内设一个接地端子，并按其需要分别制成一个（M6 及以下）或二个（M8 及以上）出线口。在接线盒座与接线盒盖的止口处加设“O”型密封圈。

4.2 电动机转轴旋转部位采用“V”型轴封环保护。

4.3 电动机机座号 80 ~ 225 的轴承采用密封轴承，机座号 250 及以上电动机设置了不停机注、排油装置。

4.4 电动机主体结构见图 1、接线盒结构见图 2。

5 防爆要点

5.1 本系列电动机为隔爆型。若电动机内部的可燃易爆性混合物爆炸时，隔爆型电动机外壳不应损坏或产生影响隔爆性能的变形；内部爆炸火焰不允许通过电机的隔爆接合面引起外部爆炸性混合物的爆炸。

5.2 隔爆型电动机的元件（如机座、端盖、轴承内盖、接线盒盖、接线盒座等），精加工后须经压力为 1.5Mpa，加压时间为 10S+2 的静压试验，以不滴水为合格。

5.3 隔爆接合面的长度、间隙、表面粗糙度、接线盒内部裸露导体之间、裸露导体与金属外壳之间的电气间隙及爬电距离应符合 GB/T3836.3 的规定。

5.4 联接隔爆外壳的螺栓均装有弹簧垫圈，防止自行松脱。

5.5 机座、端盖、轴承内盖、接线盒盖、接线盒座、接线螺栓、端子套（或接线板）、轴流风机、轴、橡胶密封圈是隔爆元件。

5.6 在额定工作状态下，电动机外壳表面温度，煤矿用不超过 +130℃，进线口外的温度不得高于所用电缆的允许温度。

5.7 电机外壳紧固螺栓应保证抗拉强度 $\geq 800\text{MPa}$ ，屈服强度 $\geq 640\text{MPa}$ 。

6 安装与使用

警告！



严禁带电开盖！

搬运电动机时，应小心谨慎！

强烈的摔、碰、震会严重损坏轴承及隔爆元件。

吊装带有吊攀的电机时，一定要将吊攀旋紧。

6.1 安装前的准备

- 6.1.1 仔细检查电动机外观是否完好、核对电动机铭牌内容是否与实际需求相符。
- 6.1.2 电动机是否有防爆标志、防爆合格证编号和生产许可证。
- 6.1.3 隔爆外壳各零部件联接正确，紧固可靠无松动。
- 6.1.4 所有隔爆元件应无裂纹或影响隔爆性能的缺陷。
- 6.1.5 取下接线盒盖检查电动机定子绕组绝缘电阻应不低于 20 MΩ。

6.2 安装

- 6.2.1 电动机的安装应由专业技术人员完成。
- 6.2.2 电动机宜采用弹性联轴器传动。
- 6.2.3 电动机轴中心与被传动的主机轴中心要保持一致。
- 6.2.4 对带底脚的电动机，安装平面应平整、坚固。
- 6.2.5 联接电动机的电源线（电缆）不宜过细、过长。

6.2.6 电缆的外径要与密封圈（图 3）的孔径相符。使用电缆最小直径为 D1，最大直径为 D5，密封圈材质为橡胶 XH-21，规格及尺寸见表 5（可根据引入电缆外径大小剥去密封圈同心圆）。配合直径差不大于 1mm，当压紧接线头后，应保证密封圈与电缆之间及密封圈与接线盒座之间无间隙，否则将失去隔爆性能。

6.2.7 引入的电缆芯线要接在两弓型垫圈之间，注意芯线的飞刺不要突出，引入接线孔时应防止线芯损伤，引入电缆还须用接线压板和弓形垫圈压紧固定，防止窜动。

6.2.8 六端子接线盒通过连接片改变接法，可适应两种不同电压需要（见接线盒盖内侧）。对有两个进线口的接线盒，当引入一根多芯电缆只使用一个进线口时，另一个进线口的堵棒不得拿掉，否则将失去防爆性能。



图 3

表 5

机座号	进线方式	密封圈形式	D1	D2	D3	D4	D5	D	b1	b
80~132	橡套电缆	图 3	φ 14	φ 20			φ 25	φ 42 0 -0.62	24	26
160~180			φ 14	φ 20	φ 26	φ 31	φ 35	φ 58 0 -0.74	24	26
200~225			φ 20	φ 26	φ 32	φ 38	φ 42	φ 72 0 -0.74	30	32
250~280			φ 25	φ 31	φ 36	φ 45	φ 50	φ 90 0 -0.87	36	38
315~355			φ 40	φ 46	φ 50	φ 56	φ 64	φ 105 0 -0.87	44	46

6.2.9 电动机的相序 U、V、W 须与接入外电源相序 A、B、C 相对应，电动机转向从轴伸端视之为顺时针方向，否则电动机将反转。

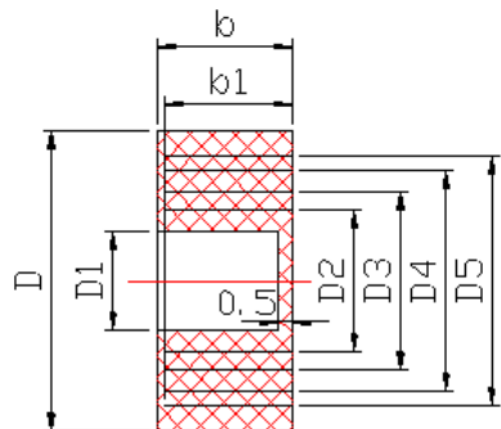
6.2.10 电动机内、外接地螺栓必须可靠接地。

6.2.11 电动机接好线，经检查确认无误后，方可接通电源进行空载试运转，并观察电机有无异常现象，待空转正常后方可投入负载运行。

警告！



- 1、电源电压的波动不得超过额定电压的 95% ~ 105%。
- 2、必须接好接地线。
- 3、电机运行若有异常立即停机。
- 4、保持身体、衣物远离电动机运转部分。

7 保养与维修

7.1 电动机应定期检查和清洁，外壳不得堆积灰尘，不得用水龙头喷射清扫电机。

7.2 对于存储半年的电动机，建议每 2 个月将电机轴旋转 180 度；存储超过半年的，通电运转一段时间，使轴承润滑脂分布均匀。

7.3 电动机运行时轴承允许温度不得超过 95 °C（温度计法），轴承每运行 2500 小时（约半年）至少检查一次，如发现轴承润滑脂变质必须及时更换，更换前，须将轴承外盖、贮油盒内的废油以及排油装置的油管、油杯清理干净，并用汽油将轴承清洗干净，润滑脂推荐采用锂基润滑脂 2 号，加脂量 2 极电机为轴承室容积的 1/3 ~ 1/2，4 极及以上为 2/3。轴承牌号见表 6。

7.4 拆装电动机时应注意保护隔爆面。H80 ~ 132 机座号的电机没有轴承内外盖。拆卸电动机时，应先拆掉风机、再拆掉轴伸端的“V”型轴封环，拆去前端盖、后端盖的固定螺栓，将后端盖连同转子连体抽出。装配时，所有隔爆面需涂 204-1 防锈脂。

7.5 电机受潮后，必须经干燥处理后方可使用。干燥处理可采用烘干或短路电流法。在烘焙过程中，温度应逐渐升高，但不可超过 145°C。用短路电流法干燥时，（严重受潮的电机不宜用此方法，以免发生电解现象。）电机处于短路状态，其输入电流为 0.6 ~ 0.8 倍额定电流值为宜。

7.6 更换绕组时，须记下原绕组的型式、尺寸、线规、匝数。当失落这些数据时，应向我公司索取。随意改变设计绕组会使电动机某项或几项性能恶化，以致不能使用。

7.7 防爆零部件维修、更换，须由专业技术人员按有关技术标准进行维修、验收。

表 6

机座号	极 数	轴伸端	非轴伸端
80	2, 4, 6, 8	6204-2RZ	6204-2RZ
90	2, 4, 6, 8	6205-2RZ	6205-2RZ
100	2, 4, 6, 8	6206-2RZ	6206-2RZ
112	2, 4, 6, 8	6206-2RZ	6206-2RZ
132	2, 4, 6, 8	6308-2RZ	6308-2RZ
160	2, 4, 6, 8	6309-2RZ	6309-2RZ
180	2	6311-2RZ	6211-2RZ
	4, 6, 8		6311-2RZ
200	2, 4, 6, 8	6312-2RZ	6312-2RZ
225	2	6312-2RZ	6312-2RZ
	4, 6, 8	6313-2RZ	6312-2RZ
250	2	6313	6313
	4, 6, 8	6314	6313
280	2	6314	6314
	4, 6, 8	6317	6314
315	2	6317	6317
	4, 6, 8, 10	NU319	6319
355	2	6319	6319
	4, 6, 8, 10	NU322	6322



图1 电动机主体结构



图2 接线盒结构

We are truly grateful for your purchasing of Wannan Motors. Before using the motor, please scan the QR code to read the manual so as to use and maintain the motor in a right way.

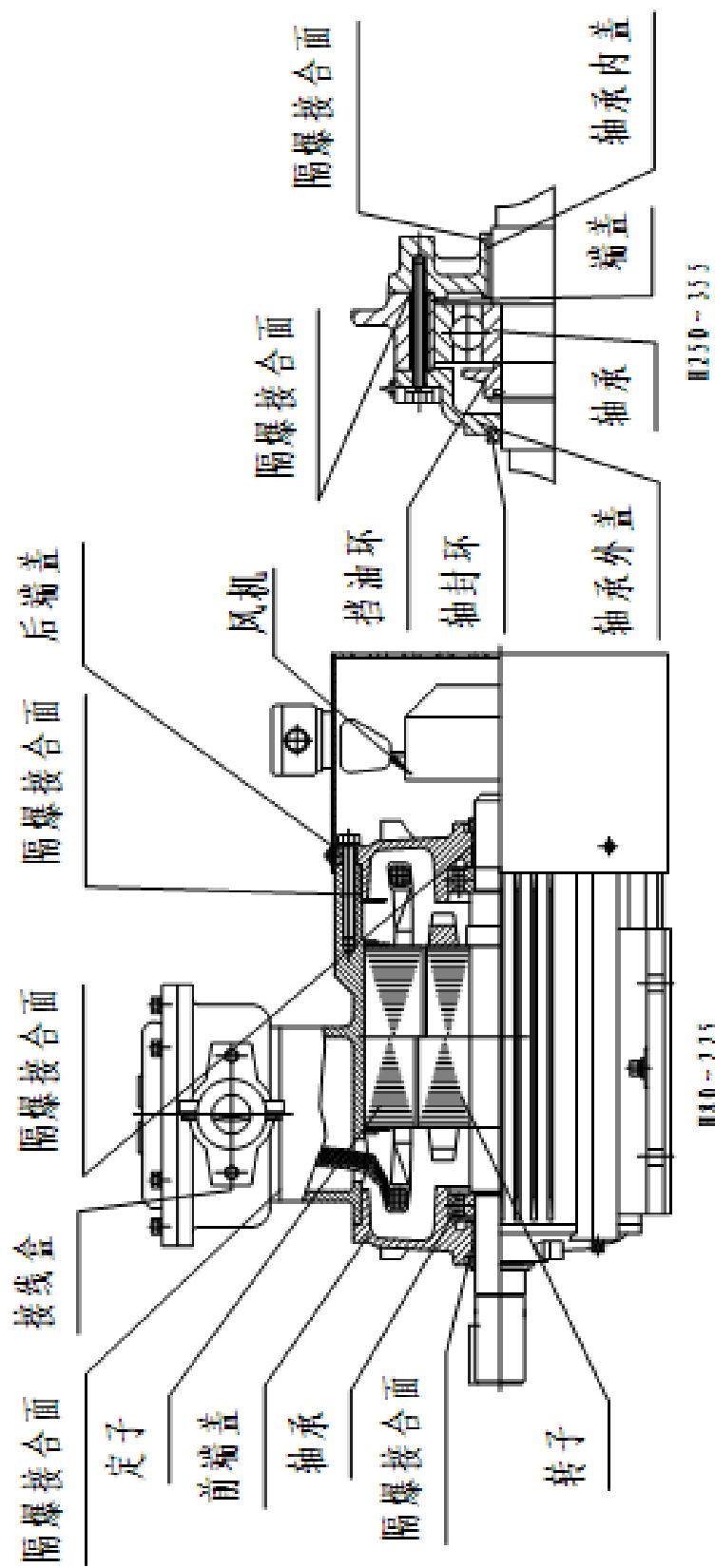
1. Summary

YBBP series flameproof variable-frequency adjustable-speed asynchronous motors, the derivation motor of YB3 explosion-proof three phase induction -proof motor, has acquired the “certification of conformity of an instrument for explosion atmosphere” from CQST(China national Quality Supervision and Test center for explosion protected electrical products) and “national industrial product manufacture licensing certificated” from “General Administration of Quality supervision, inspection and Quarantine of the people’s republic of China”.

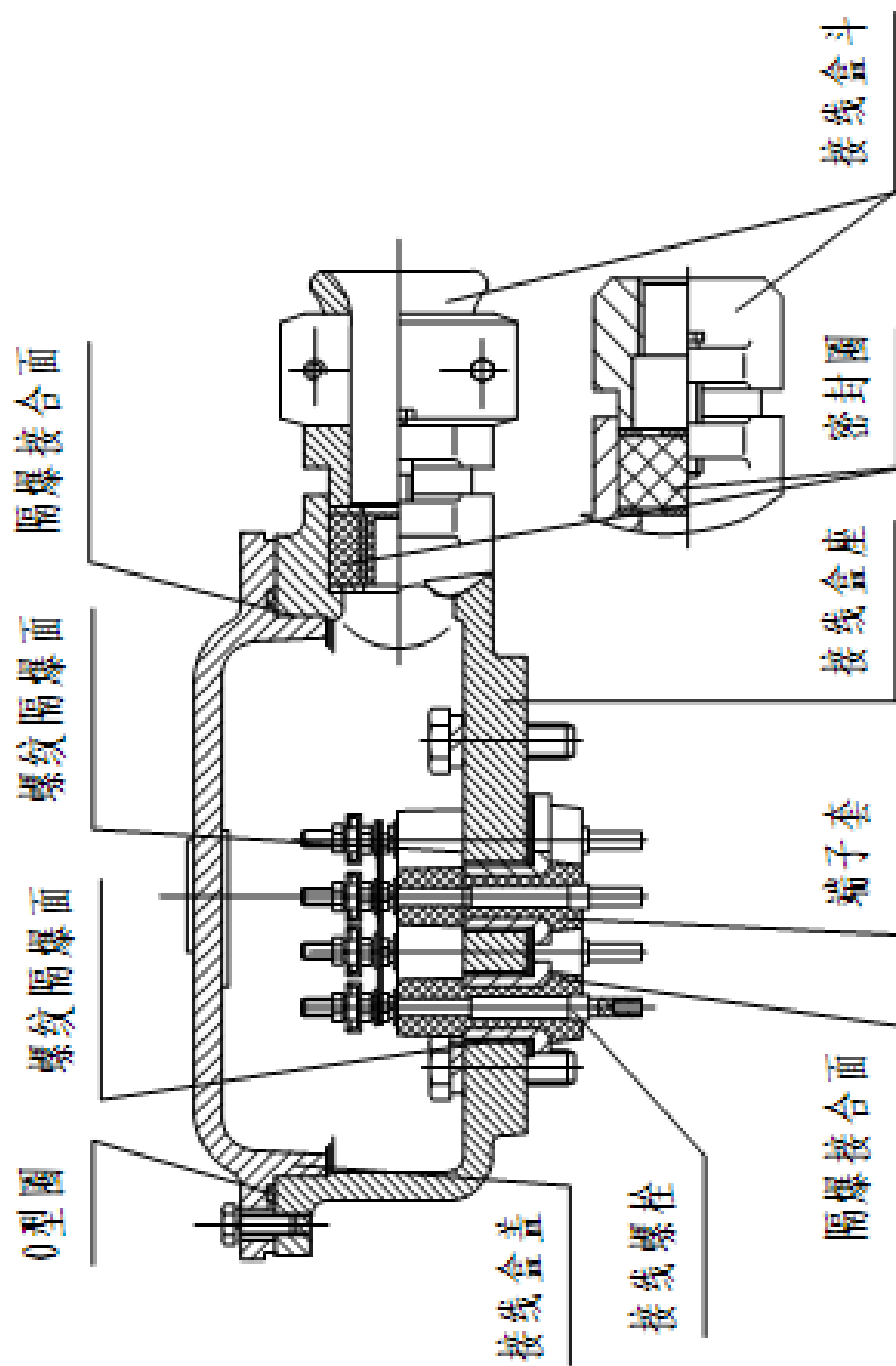
YBBP series motor of our company are found to be in conforming to the requirements of standard JB/T 11201.3-2011 “Specification for flameproof variable-frequency adjustable-speed three-phase Asynchronous motor: Part 3 The requirement of YBBP-W、 YBBP-TH 、 YBBP-THW series flameproof adjustable-speed asynchronous motors (Frame 80~355)”. The flameproof motor is manufactured according to the standard of GB 3836.1-2021 “Part 1 of Electrical equipment used in explosive environment: General Requirement” and GB3836.2-2021“Part 2 of Electrical equipment used in explosive environment: The Apparatus with the flameproof enclosure “d”. The products, marked with Ex d II AT4 Gb、 Ex d II BT4 Gb, can be used in workshop where there is Category II Class A and B flammable gas or the flammable mixture of air and steam in Temperature Group T1~T4.

2. Designation and types

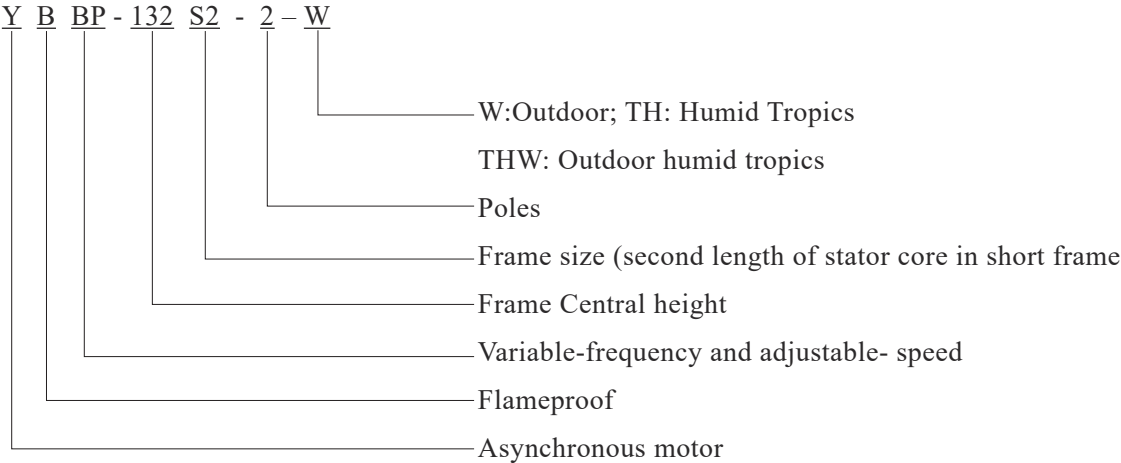

3. Application circumstance

3.1 The applicable common inflammable gas, steam and temperature groups are listed in the table 1 below:

Table 1

Type	Temperature Groups			
	T1	T2	T3	T4
II A	Methane, ethane, propane, styrene, toluene, xylene, carbon monoxide, acetic acid	Butane, propane, ethyl benzene, methanol, ethanol, propyl alcohol, Benzene alcohol	Pentane, hexane, heptane, octane, decane, cyclohexane kerosene, diesel oil, gasoline	
II B	Propine, cyclopropane, coke oven gas	Ethylene, butadiene epoxy ethane, epoxy propane	Dimethylether, propylene aldehyde, ydrogen furfuryl alcohol furan, hydrogen sulfide	ethyl methyl ether, diethyl ether, tetrafluoroethylene

3.2 Operating condition

3.2.1 Not exceed 1000m above the sea level.

3.2.2 Ambient temperature varies as seasonal variation, but the temperature shall not beyond the range $-15^{\circ}\text{C} \sim +40^{\circ}\text{C}$.

3.2.3 The maximum environment relative humidity shall be no more than 90%, besides mean minimum temperature of this month shall be no higher than 25°C

3.2.4 Motor's rated voltage is 380V, rated frequency 50Hz, F insulation class.

3.2.5 Motor of 3kw and below shall adopt Y connection, but the motor over 3kw ought to be connected as Δ type.

3.2.6 The rating here refers to the continuous rating power on the basis of S1 operation system, the motor allows direct starting.

3.2.7 The surface temperature of motor casing (by thermometer method) shall be no higher than 130°C even it is working under the most severe condition defined by provision.

3.2.8 Deviation of voltage and frequency from the rating value at the motor running time shall be in accordance with the standard of GB/T755 .

3.3 Main technical parameter see table 2 and table 3.

Table 2 Motor frame's relation to nominal power and speed

Frame Size	Synchronous Speed r/min				
	3000	1500	1000	750	600
	Power kW				
80M1	0.75	0.55	0.37	0.18	-
80M2	1.1	0.75	0.55	0.25	
90S	1.5	1.1	0.75	0.37	

Table 2 (continued)

Frame Size	Synchronous Speed r/min				
	3000	1500	1000	750	600
	Power kW				
90L	2.2	1.5	1.1	0.55	
100L1	3	2.2	1.5	0.75	
100L2		3		1.1	
112M	4	4	2.2	1.5	
132S1	5.5	5.5	3	2.2	
132S2	7.5				
132M1	-	7.5	4	3	
132M2			5.5		
160M1	11	11	7.5	4	
160M2	15			5.5	
160L	18.5	15	11	7.5	
180M	22	18.5	-	-	
180L	-	22	15	11	
200L1	30	30	18.5	15	
200L2	37		22		
225S	-	37	-	18.5	
225M	45	45	30	22	
250M	55	55	37	30	
280S	75	75	45	37	
280M	90	90	55	45	
315S	110	110	75	55	45
315M	132	132	90	75	55
315L1	160	160	110	90	75
315L2	200	200	132	110	90
355S1	(185)	(185)	160	132	
355S2	(200)	(200)			
355M1	(220)	(220)	(185)	160	110
355M2	250	250	200		132
355L1	(280)	(280)	(220)	(185)	160
355L2	315	315	250	200	(185)

Tips 1.Type with () refers to not prioritized recommendation product specification.
2.The figures 1、 2 behind S、 M、 L refer to different output power of the motors with the same frame and speed.

Table3 Motor nominal power's relation to torque and frequency regulation range

Nominal Power	Torque N·m					Constant Torque Hz	Constant Power Hz	
	2P	4P	6P	8P	10P			
0.18	-	-	-	2.2	-	5-50	50-100	
0.25			-	3.1				
0.37			3.5	4.7				
0.55			3.5	5.2				7.0
0.75			2.3	4.7				7.1
1.1	3.5	7.0	10.5	14.0	-			
1.5	4.7	9.5	14.3	19.0				
2.2	7.0	14.0	21.0	28.0				
3	9.5	19.0	28.6	38.1				
4	12.7	25.4	38.1	50.8				
5.5	17.5	35.0	52.5	70.0				
7.5	23.8	47.7	71.6	95.4				
11	35.0	70.0	105.0	140.0				
15	47.7	95.4	143.2	191.0				
18.5	58.8	117.7	176.6	235.5				
22	70.0	140.0	210.0	280.1				
30	95.4	190.9	286.4	382.0				
37	117.7	235.5	353.3	471.1				
45	143.2	286.4	429.7	573.0				716.2
55	175.0	350.1	525.1	700.3				875.4
75	238.7	477.7	716.1	955.0	1193.7	3-50		
90	286.4	572.9	859.4	1146.0	1432.5			
110	350.1	700.2	1050.3	1400.6	1750.8			
132	420.1	840.3	1260.4	1680.8	2101.0			
160	509.2	1018.5	1527.8	2037.3	2546.6			
(185)	588.6	1177.6	1766.5	2355.6	2944.5			
200	636.6	1273.2	1909.8	2446.6	-			
(220)	700.2	1400.4	2100.9					
250	795.7	1591.5	2387.2					
(280)	891.2	1782.5						
315	1002.6	2005.2						

3.4 Motor Structure and installation type see table 4

Table 4

Frame	Structure and Installation Code (IM)
80~160	B3、B5、B6、B7、B8、B35、V1、V3、V5、V6、V15、V35、V37
180~280	B3、B5、B35、V1
315~355	B3、B35、V1

4. Subject structure

4.1 Terminal box, at the top of the motor, has 6 connection terminals. This series motors have 2 kinds of wiring structure: rubber cable (plastic cable) and steel pipe wiring, each with 1 grounding terminal, and can be made with 1 (M6 and below) or 2 (M8 and above) cable outlet Rabbet between terminal box body and it's cover shall be fitted with sealing ring.

4.2 Motor is fitted with V-sealing ring to protect motor shaft's rotation part.

4.3 Motor of frame 80~225 adopt seal bearing, motor of frame 250 or above adopt on-the-go refueling and discharging device.

4.4 Subject structure of the motor see figure 1, and the structure of terminal box see figure 2.

5. Flameproof feature

5.1 The series motor highlights its flameproof feature. If the explosive mixture inside the motor explodes, the motor casing shall not be damaged or deformed to the extent that may affect its flameproof performance; the flame inside can not pass through conjunction plane to explode external flammable mixture.

5.2 Drilled components of the flameproof motor (such as frame, end cap, bearing inner cover, connection box cover, connection box body etc) should be tested with 1.5Mpa static pressure for 10S+2 and will be checked as qualified only by without dripping during or after the test.

5.3 The length of the flameproof conjunction plane, clearance, roughness of the surface, the creepage distance and electric clearance among bare conductors or between bare conductor and metal casing, all shall be in accordance with GB3836.3

5.4 Spring washer on fastening bolt can prevent the bolts releasing from flameproof casing.

5.5 Frame, end cover, bearing inner cover, terminal box cover, terminal box body, terminal array (or terminal block), axis fan, shaft, rubber seal ring are all flameproof components.

5.6 Operate in the rated condition, the coal mine purpose motor casing's max temperature shall not exceed +130℃ ; temperature at cable entry shall be no higher than the limit temperature of each cable there-through.

6. Installation and usage



Warning!

To open the cover with power on is forbidden.

Handle the motor with care.

Strong fall, impact, vibration will heavily damage bearing and flameproof component.

Fasten onto the lifting hook tightly if the motor is moved by the crane.

6.1 Preparation

6.1.1 Check and ensure the appearance of the motor is in good order. Check and ensure that the motor nameplate is consistent with actual requirement.

6.1.2 Inspect the motor's ex-code, ex-certificate No. and manufacture license.

6.1.3 Ensure that all parts of explosion-proof casing have been connected correctly and tightly.

6.1.4 Check and ensure that all explosion-proof components have neither crack nor defect that affects its explosion-proof performance.

6.1.5 Check and measure the insulation resistance of the stator winding, and ensure that the

resistance value is no less than 20MΩ.

6.2 Installation

6.2.1 Installation shall be performed by technician.

6.2.2 Spring coupling is recommended be used to drive machine. .

6.2.3 Keep the motor shaft's center and driven machine shaft's center at the same level.

6.2.4 For the motor with feet, all the feet shall be fixed to sound and flat plane.

6.2.5 Power wires shall be neither too thin nor too long.

6.2.6 External diameter of the cable should fit bore diameter of the seal ring (Figure 3). Cable's min diameter is D1, max is D5; seal ring is made of rubber XH-21, specification and dimension see table 5 (concentric-ring of seal gasket can be stripped off to fit inner diameter of lead-in cable). The diameter gap should not exceed 1mm. Clamp the connection plug and ensure that there is no clearance between seal ring and power cable as well as between seal ring and connection box body, otherwise the motor will lose its flameproof function.

6.2.7 The cable core shall be attached between arched washers, and thorn on the cable corn can't be protruding in case of core damaging when pulling it out through cable entrance. The lead-in cable shall be fixed by connection board and arched washer to avoid movement.

6.2.8 To fit different supply voltage, different connection method shall be chosen (see inner side of terminal box cover). For the connection box with terminals, one can change the connection type by changing its connection strap. In case there were 2 cable entrance and if one multi-core cable was introduced into one of the two, the blank cover at the other entrance can't be removed; otherwise the motor will lose its explosion-proof function.

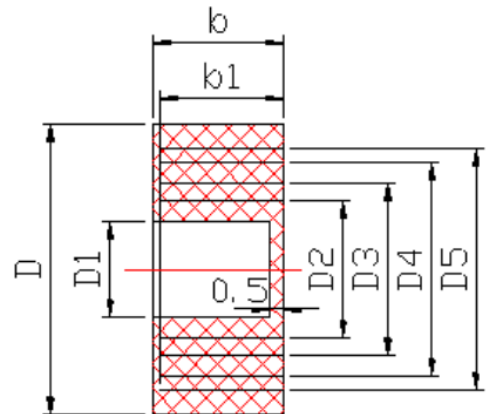

Figure 3

Table 5

Frame	Cable	Sealing ring	D1	D2	D3	D4	D5	D	b1	b
80~132	Rubber-sheathed cable	Fig 3	Φ14	Φ20			Φ25	Φ42 0 -0.62	24	26
160~180			Φ14	Φ20	Φ26	Φ31	Φ35	Φ58 0 -0.74	24	26
200~225			Φ20	Φ26	Φ32	Φ38	Φ42	Φ72 0 -0.74	30	32
250~280			Φ25	Φ31	Φ36	Φ45	Φ50	Φ90 0 -0.87	36	38
315~355			Φ40	Φ46	Φ50	Φ56	Φ64	Φ105 0 -0.87	44	46

6.2.9 Motor will rotate clockwise viewed from DE if the terminals U,V,W are connected to power line phase A, B, C respectively. Otherwise the motor will rotate anti-clockwise.

6.2.10 Internal and external grounding screw bolts need to be grounded safely.

6.2.11 Check the motor and confirm that there is no mistake, power on and make the motor no-load running test. When all runs smoothly the motor can be put into load operation.



Warn!

1. Supply voltage fluctuation shall not go beyond the range 95% ~105% of the rated voltage.
2. Ground wire must be connected
3. Turn off the motor immediately when abnormal problem occurs.
4. Keep body and clothes far away from rotating parts of motor.

7. Maintenance and inspect

7.1 Examined and clean the motor periodically, ensure that no dust accumulated on motor casing, spraying with tap for cleaning is not allowed.

7.2 Turn the shaft by 180° with hand every 2 month for the motor which has been stored half year; the motor need to work for a period of time to make the lubrication grease equidistribution when the motor has been stored longer than half year.

7.3 The permitted maximum temperature of bearing should not exceed 95°C during its operation (by thermometer method), inspect once or more every 2500-hour running (approximate half a year). Bearing lubrication grease shall be replaced when it is found to be spoiled. Before that the waste grease at bearing external cover, storage box, grease discharging device including oil tube and oil cup should be cleaned up, and clean the bearing with machine oil. No.2 Lithium-base lubricating grease is recommended. For 2P motor, it's proper to fill 1/3~1/2, for 4P or above motor to fill 2/3 capacity of the bearing chamber with lubrication grease. Bearing specification see table 6.

7.4 Explosion-proof plane shall be protected with care if the motor need to be dismantled. Frame H80~132 Motors have no internal and external bearing cover, so wind blower should be removed at first, then the V-shape shaft sealing ring, knock down the fastening bolts on front and rear end closure, and take out the rear end closure together with the rotor. Explosion proof plane of the motor ought to be painted with 204-1 rust protection grease in assembling processes.

7.5 In case that the motor is dampened, before operation it need to be firstly dried by means of heating or short-circuit current. When dry by the former method, the temperature should rise gradually, yet the maximum mustn't be higher than 145°C . When dried by the latter method, it's proper to input 0.6~0.8 time of the rated current under short-circuit condition (but the motor that has been got damp severely is unfit to adopt short-circuit current method since it may cause electrolyzation).

7.6 When the winding need to be replaced, please record its type, size, wire diameter, number of turns and ensure the new one is the same with the original ones. Contact us in case the data are lost.

Winding can not be optionally changed, otherwise some of the motor's properties may be deteriorated or even affect its running.

7.7 Explosion-proof components should be repaired, replaced, tested by technician following relevant technical standards.

Table 6

Frame	Poles	DE	NDE
80	2,4,6,8	6204-2RZ	6204-2RZ
90	2,4,6,8	6205-2RZ	6205-2RZ
100	2,4,6,8	6206-2RZ	6206-2RZ
112	2,4,6,8	6206-2RZ	6206-2RZ
132	2,4,6,8	6308-2RZ	6308-2RZ
160	2,4,6,8	6309-2RZ	6309-2RZ
180	2	6311-2RZ	6211-2RZ
	4,6,8		6311-2RZ
200	2,4,6,8	6312-2RZ	6312-2RZ
225	2	6312-2RZ	6312-2RZ
	4,6,8	6313-2RZ	6312-2RZ
250	2	6313	6313
	4,6,8	6314	6313
280	2	6314	6314
	4,6,8	6317	6314
315	2	6317	6317
	4,6,8,10	NU319	6319
355	2	6319	6319
	4,6,8,10	NU322	6322

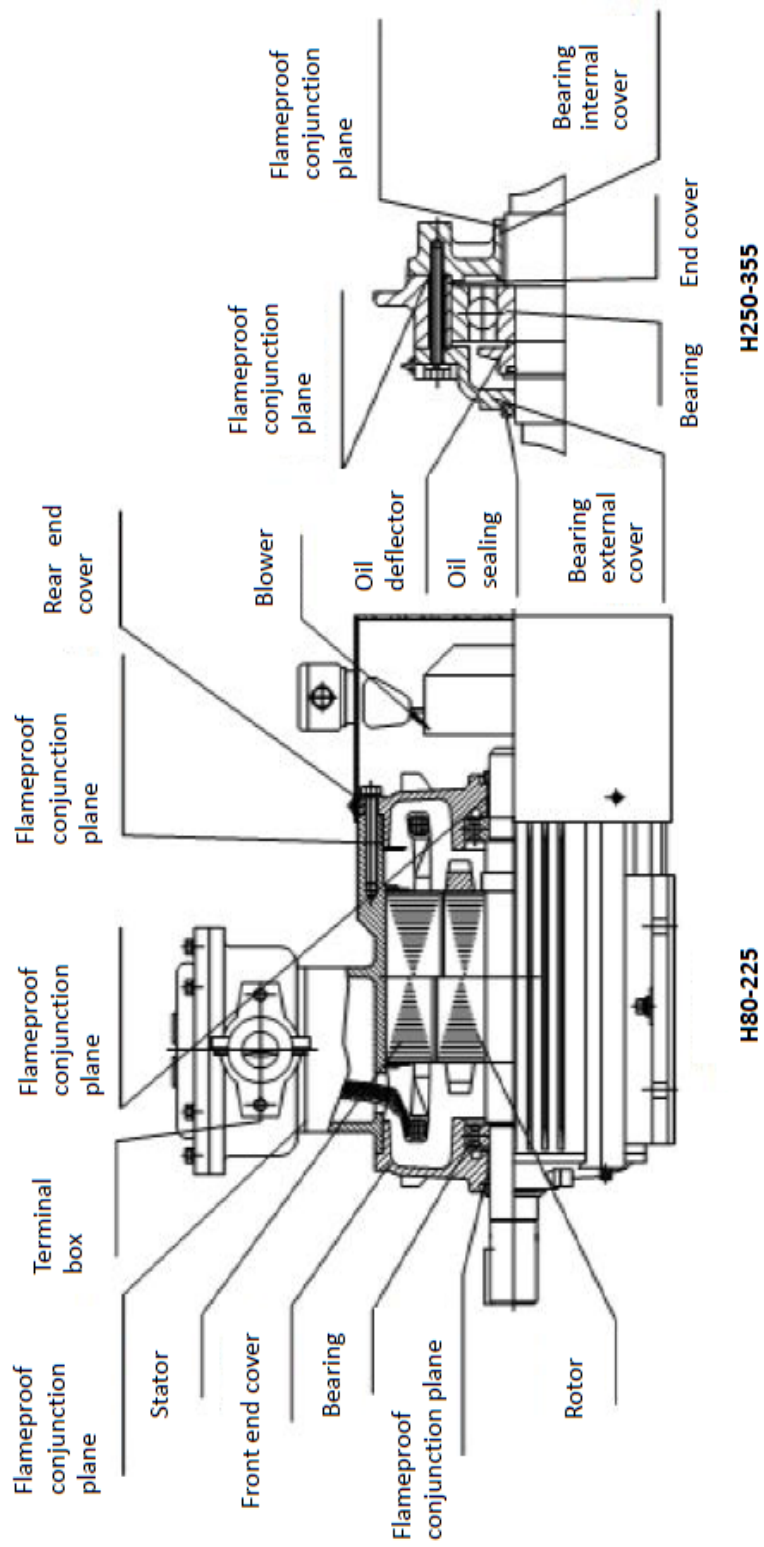

Figure 1 Subject structure

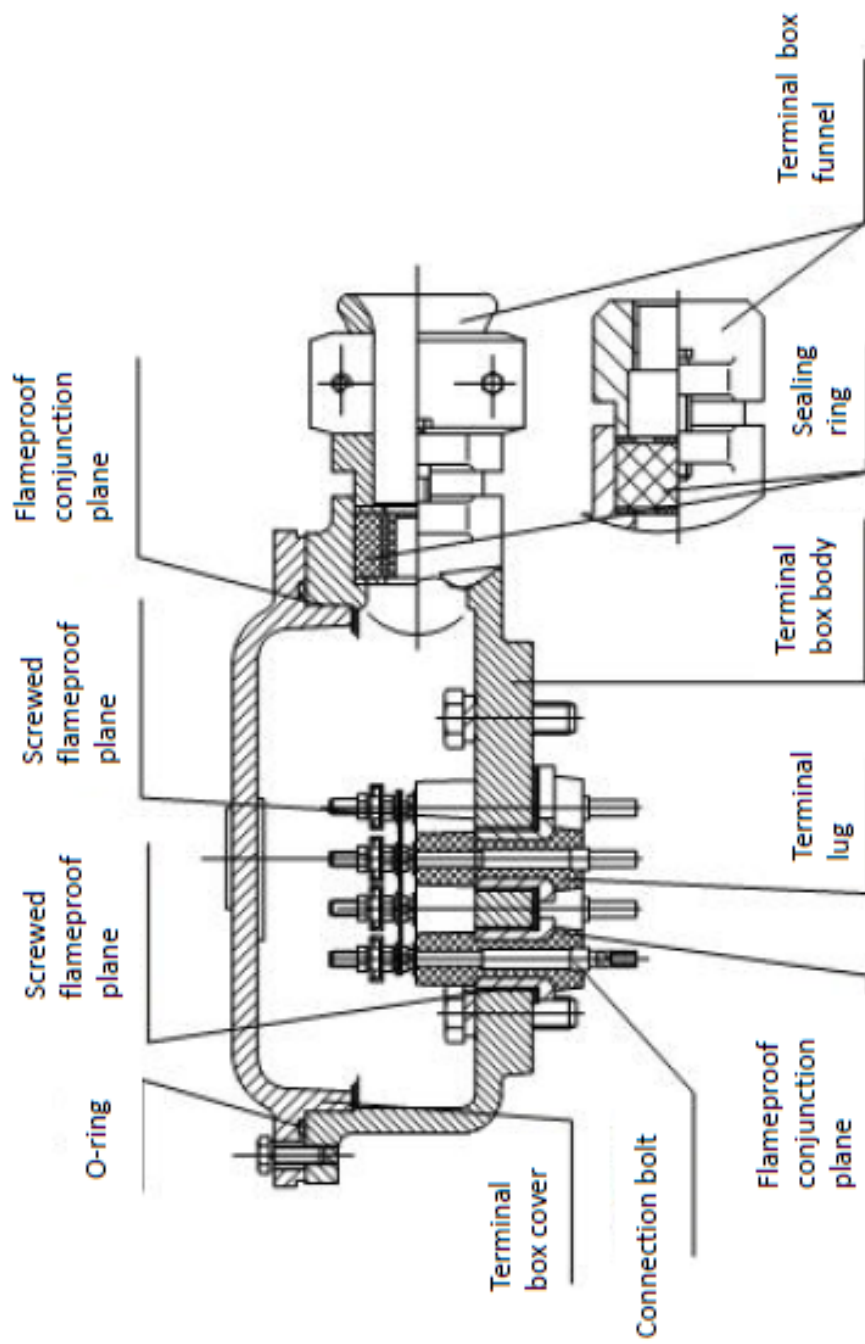

Figure 2 Terminal box structure

敬告用户：

请您按照本使用说明书的规定，正确地使用和储存电动机，我们将为您提供优质、快捷的服务。

在电动机使用过程中，您如有什么疑惑请与我们联系，我们将及时给予您满意的解答；您有什么良好的建议请向我们提出，以便我们改进，为您提供优质、快捷的服务。

安徽皖南电机股份有限公司对本使用说明书保留最终解释权。

请勿在未事先获得安徽皖南电机股份有限公司书面许可的情况下向第三方复制、公布或者使用本使用说明书内容。

Dear user,

Please use and store the motor right following the instruction of the manual. We will make our effort to provide you with high-quality and prompt service. Contact us if you had any questions in application, and we will offer you timely and effective resolution; let us know if you had any advices or suggestions, with which we can improve ourselves and make service better. Anhui Wannan Motor Co., Ltd. reserves the right of final interpretation of the user manual. No copy, disclosing or using of the content of this user manual to third parties prior to written permission from Anhui Wannan Motor Co., Ltd.

安徽皖南电机股份有限公司

Anhui Wannan Electric Machine Co.,Ltd

地址：安徽省泾县泾川镇南华路 86 号

Address: No.86 Nanhua Road Jingxian County Anhui Province P.R.C

销售处 Sales department: 400-111-0563 0563-5031908 5031988

客户服务中心 Customer service center: 0563-5031953

企业管理处 Enterprises management department: 0563-5031954

质量检验处 Quality inspection department: 0563-5031910 5031985

传真 Fax: (0563) 5029999 5023698

网址 Website: <http://www.wnmotor.com>

E-mail: wndjc@wnmotor.com

邮编 Postal code: 242500

本说明书内容如有变动，恕不另行通知。

Content in the manual may be changed without prior notice.